

SETTING MANUAL

SERVICE TOOL for VRF System

UTY-ASGX

Ver. 1.0



CAUTION

Please read the LICENSE AGREEMENT in the manual first.

9708313023-01

FUJITSU GENERAL LIMITED

LICENSE AGREEMENT for “SERVICE TOOL for VRF SYSTEM” (Version 1.0)

IMPORTANT-READ CAREFULLY

This “SERVICE TOOL for VRF SYSTEM” License Agreement (LICENSE AGREEMENT) is a legal agreement between you and Fujitsu General Limited (FGL) for the use of VRF SERVICE TOOL products designated below, which includes computer software and printed materials, and may include online or electronic documentation (SOFTWARE PRODUCT or SOFTWARE). By installing, copying, or otherwise using the SOFTWARE PRODUCT, you accept to be bound by all of the terms and conditions of this LICENSE AGREEMENT. If you do not agree to all of the terms and conditions of this LICENSE AGREEMENT, you may not use the SOFTWARE PRODUCT and shall promptly return the SOFTWARE PRODUCT to the place from which you have obtained it.

1. SOFTWARE PRODUCT LICENSE

The SOFTWARE PRODUCT is protected by copyright laws and international copyright treaties, as well as by other intellectual property laws and treaties. The SOFTWARE PRODUCT is licensed to you, not sold. FGL owns the title, copyright, and other intellectual property rights in the SOFTWARE PRODUCT.

2. GRANT OF LICENSE

FGL hereby grants you the limited, non-exclusive and non-transferable rights only for the purpose of maintaining and testing VRF air-conditioning system products (VRF) provided you comply with all terms and conditions of this LICENSE AGREEMENT.

3. COPYRIGHT

All right, title, and copyright in and to the SOFTWARE PRODUCT, and any copies of the SOFTWARE PRODUCT are owned by FGL. The SOFTWARE PRODUCT is protected by copyright laws and international treaty provisions. Therefore, you may copy the SOFTWARE PRODUCT solely for backup or archival purposes.

4. DESCRIPTION OF OTHER RIGHTS AND LIMITATIONS

(1) USE OF SOFTWARE PRODUCT

You may install and use the enclosed SOFTWARE PRODUCT on a single terminal connected to a single computer. You may not network the SOFTWARE or otherwise use it on more than one computer terminal at the same time. The infrastructure necessary to use this software (PC, accessories, etc.), shall be prepared separately by you.

(2) LIMITATIONS ON REVERSE ENGINEERING, DECOMPILATION, AND DISASSEMBLY

You may not reverse engineer, decompile, or disassemble the SOFTWARE PRODUCT, except and only to the extent that applicable law expressly permits such activity notwithstanding this limitation.

(3) RENTAL

You may not rent or lease the SOFTWARE PRODUCT.

(4) SOFTWARE TRANSFER

You may not transfer the SOFTWARE PRODUCT to any person and/or entity (-ies) either payable or free of charge without the written consent of FGL.

(5) TERMINATION

Without prejudice to any other rights, FGL may terminate this LICENSE AGREEMENT if you fail to comply with the terms and conditions of this LICENSE AGREEMENT.

In such an event, you shall promptly return all originals and copies of the SOFTWARE PRODUCT to FGL.

5. EXPORT RESTRICTIONS

You acknowledge that the SOFTWARE PRODUCT is of Japan origin. You agree that neither you nor your customers intend to or will, directly or indirectly, export or transmit the SOFTWARE PRODUCT to any country to which such export or transmission is restricted by any applicable regulation or statute, without the prior written consent, if required, of the authorized governmental entity as may have jurisdiction over such export or transmission.

6. NO WARRANTY

TO THE MAXIMUM EXTENT PERMITTED BY APPLICABLE LAW, FGL EXPRESSLY DISCLAIMS ANY WARRANTY FOR THE SOFTWARE PRODUCT. THE SOFTWARE PRODUCT AND ANY RELATED DOCUMENTATION IS PROVIDED "AS IS" WITHOUT WARRANTY OF ANY KIND, EITHER EXPRESSED OR IMPLIED, INCLUDING, WITHOUT LIMITATION, THE IMPLIED WARRANTIES OR MERCHANTABILITY OF FITNESS FOR A PARTICULAR PURPOSE. THE ENTIRE RISK ARISING OUT OF USE OR PERFORMANCE OF THE SOFTWARE PRODUCT REMAINS WITH YOU.

7. LIMITATION OF LIABILITY AND CUSTOMER REMEDIES

FGL'S ENTIRE LIABILITY AND YOUR EXCLUSIVE REMEDY UNDER THIS LICENSE AGREEMENT SHALL BE, AT FGL'S OPTION, REPLACEMENT OF THE SOFTWARE WHICH IS RETURNED TO FGL. THIS LICENSE AGREEMENT SHALL ALSO APPLY TO THE REPLACEMENT SOFTWARE SUPPLIED UNDER THIS SECTION 7.

8. NO LIABILITY FOR CONSEQUENTIAL DAMAGES

TO THE MAXIMUM EXTENT PERMITTED BY APPLICABLE LAW, IN NO EVENT SHALL FGL BE LIABLE FOR ANY DAMAGES WHATSOEVER (INCLUDING, WITHOUT LIMITATION, DAMAGES FOR LOSS OF BUSINESS PROFIT, BUSINESS INTERRUPTION, LOSS OF BUSINESS INFORMATION, OR ANY OTHER PECUNIARY LOSS) DIRECT OR INDIRECT, TO YOU OR TO ANY THIRD PARTY, ARISING OUT OF THE USE OR INABILITY TO USE THIS PRODUCT, EVEN IF FGL HAS BEEN ADVISED OF THE POSSIBILITY OF SUCH DAMAGES.

9. ENTIRE AGREEMENT

This LICENSE AGREEMENT (including any addendum or amendment to this LICENSE AGREEMENT included with the SOFTWARE PRODUCT) is the entire agreement between you and FGL relating to the SOFTWARE PRODUCT and supersedes all prior contemporaneous oral or written communications, proposals and representations with respect to the SOFTWARE PRODUCT or any other subject covered by this LICENSE AGREEMENT.

10. INDEMNITY

You agree to indemnify and hold FGL, and its subsidiaries, affiliates, officers, agents, co-branders or other partners, and employees, harmless from any damage, claim or demand, including without limitation reasonable attorneys' fees, made by any third party due to or arising out of your violation of the terms and conditions of this LICENSE AGREEMENT, or your violation of any rights of another person or entity.

11. GOVERNING LAW AND JURISDICTION



To the maximum extent permitted by applicable law, this LICENSE AGREEMENT is governed by the laws of JAPAN. To the maximum extent permitted by applicable law, you and FGL hereby irrevocably submit to the exclusive jurisdiction of the Tokyo District Court and other higher courts having jurisdiction in Japan for the settlement of disputes arising under or in connection with this LICENSE AGREEMENT.

Contents

1. Safety precautions	4
------------------------------------	----------

1. Safety precautions

- Before using Service Tool, read this “SAFETY PRECAUTIONS” thoroughly to ensure the correct operation.
- This section describes the important safety information to operate Service Tool.
- The meanings of “WARNING” and “CAUTION” are explained as follows.

 WARNING!	This mark indicates the procedures, which might result in the death of or serious injury to the user or service personnel if improperly performed.
 CAUTION!	This mark indicates the procedures, which might result in personal harm to the user or damage to property if improperly performed.

This manual is for service personnel authorized to use the Service Tool. Always keep this manual in an easily accessible place for use by authorized service personnel.

 WARNING!
<ol style="list-style-type: none"> 1. When using U10 USB Network Adaptor, follow the instructions given in the manual that comes with the product.

 WARNING!
<p>Service Tool can control the air-conditioner system on a personal computer. Be careful not to turn off the power supply of the personal computer, or not to finish the application compulsorily during operation. Otherwise, Service Tool might malfunction. For personal computer used as Service Tool, refer to the instruction manual.</p>

Contents

2. Outline..... 6

2. Outline

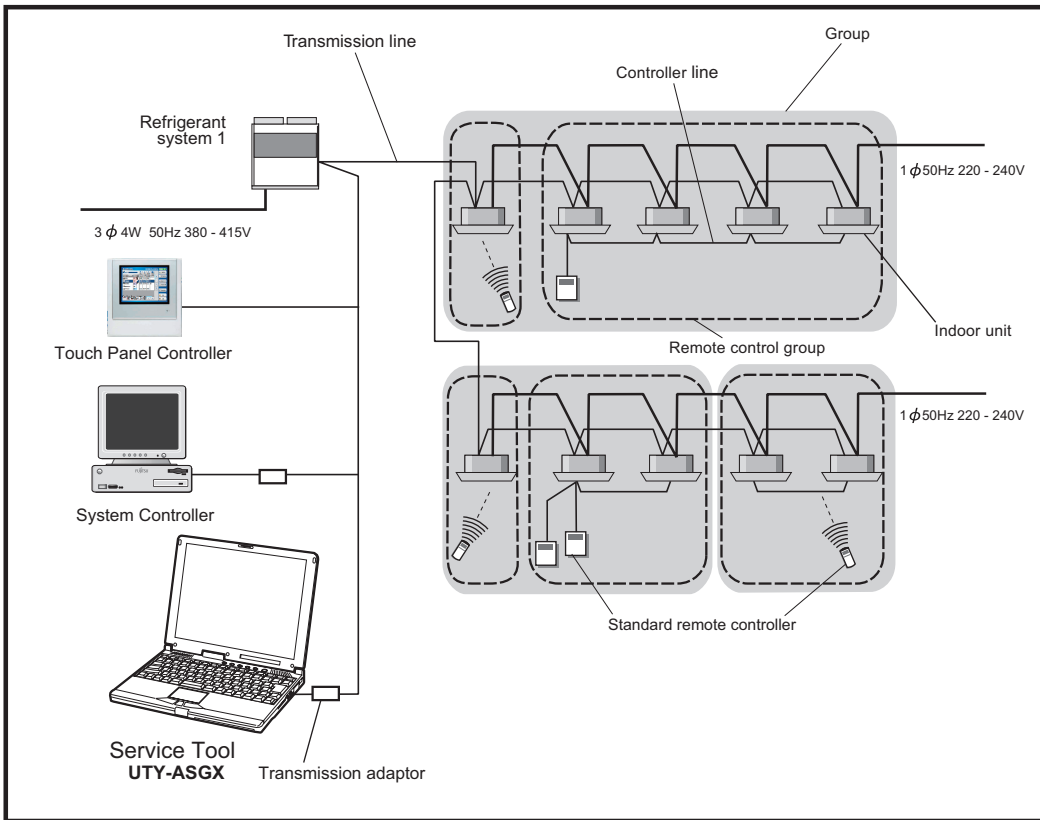

This setting manual explains the setting procedures for the software of Service Tools for the VRF control system.

The use of the system tools allows detailed data about the operating condition of each refrigerant system that has been installed in the building's system to be displayed in an easy-to-understand format.

Moreover, it also allows the latest data about pressure and temperature of indoor and outdoor units to be monitored. If there are fluctuations in the conditions, they can be displayed clearly in graph form on a PC screen.

When an error occurs in the transmission line or in an indoor or outdoor unit in the system, details about the error can be displayed on the error history screen for easy assessment of the conditions for fast troubleshooting and resolution.

■ Software construction

The Service Tool software consists of the two functions **Data acquisition application** and **WEB application** .

The **Data acquisition application** is a program which is made resident when the Service Tool starts, and exchanges data with the VRF System transmission line. The received Unit data is saved to a Data base.



The **WEB application** is a program which converts the acquired Unit data to Table and Graph, and displays them to a browser (Internet Explorer). It also converts operations input from the User and passes them to the Data acquisition application through the Database.

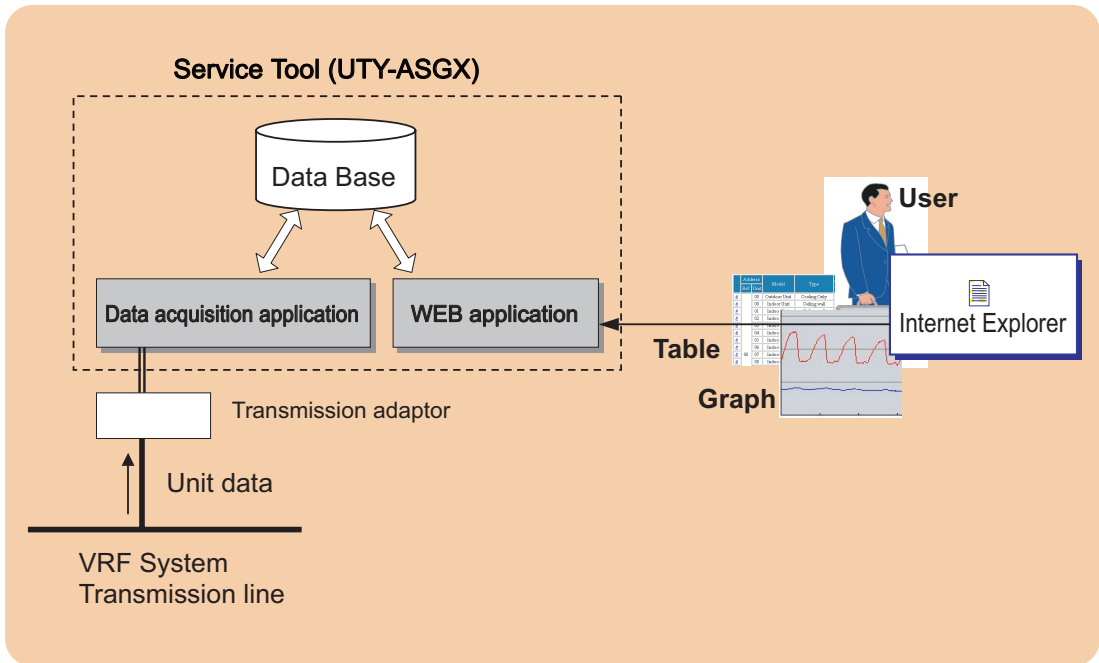

Contents

3. Installation	10
3-1 Precautions	10
3-2 Recommended specs	10
3-3 Installation flow	11

3. Installation

3-1 Precautions

- This product requires the use of one of the following optional transmission adaptors. Procure them in advance.

Name & Shapes	Q'ty	Remark
Transmission Adaptor (U10 USB Network Interface -TP/FT-10 Channel)  (Field Supply)	1	Model : 75010R (Echelon Corporation)

3-2 Recommended specs

This tool operates in the environment below.

Personal Computer		AT compatible machine that runs Microsoft® Windows®
	Operating System	Microsoft® Windows® 2000 Professional (English version / Service pack4 or later) Microsoft® Windows® XP Professional (English version / Service pack2 or later) Microsoft® Windows® Vista Home Premium, Business, Ultimate Edition. (English version)
	CPU	Intel® Pentium® / Celeron®, AMD Athlon™ / Duron™ 1GHz or higher
	HDD	4.1 GB or more of free space
	Memory	1GB (Vista), 512MB(XP/2000) or more
	Interface	USB port is required for each of the following; <ul style="list-style-type: none"> • Wibu Key (Software protection key) • Echelon® U10 USB Network Interface (Required for each VRF Network)
Software		Internet Explorer 6.0 or 7.0 / Adobe® Acrobat® Reader 4.0 or later

3-3 Installation flow

WARNING!

- Service Tool is tested to install and operate under new Windows environment. When program executional environment of Windows is corrupted or abnormal, or other softwares that interfere with the operation of Service Tool is installed or running, Service Tool may not install or run properly. It is usually extremely difficult to detect such conditions, if it occurs.
- Service Tool product is provided with softwares, drivers, components listed below. If the same kind of softwares, drivers, components with different version is installed on the same PC, Service Tool may not install or run properly.
 - 1) .NET Framework
 - 2) Internet Information Services (IIS)
 - 3) Microsoft® Data Access Components (MDAC)
 - 4) Microsoft® SQL Server 2005 Express
- If “Program Files” folder is compressed or encrypted, Microsoft® SQL Server 2005 Express cannot be installed. Release the settings before installation as follows:
Start “Explorer” → right-click “Program Files” folder → select “properties” → click “Advanced...” → release the check marks of the “Compress or Encrypt attributes”.

Hardware installation

Transmission adaptor installation

Software installation

(5-1) (5-2)

Insert installation CD

Microsoft® Net Framework 2.0 setup
Microsoft Data Access Components 2.8 (MDAC) setup
Microsoft® SQL Server 2005 Express setup

Message confirming the installation of Adobe Acrobat Reader

Continue

Cancel

Installer terminates

Internet Information Services (IIS) setup

IIS mapping information restoration

Service Tool for VRF System Ver 1.0 setup

WIBU-KEY setup

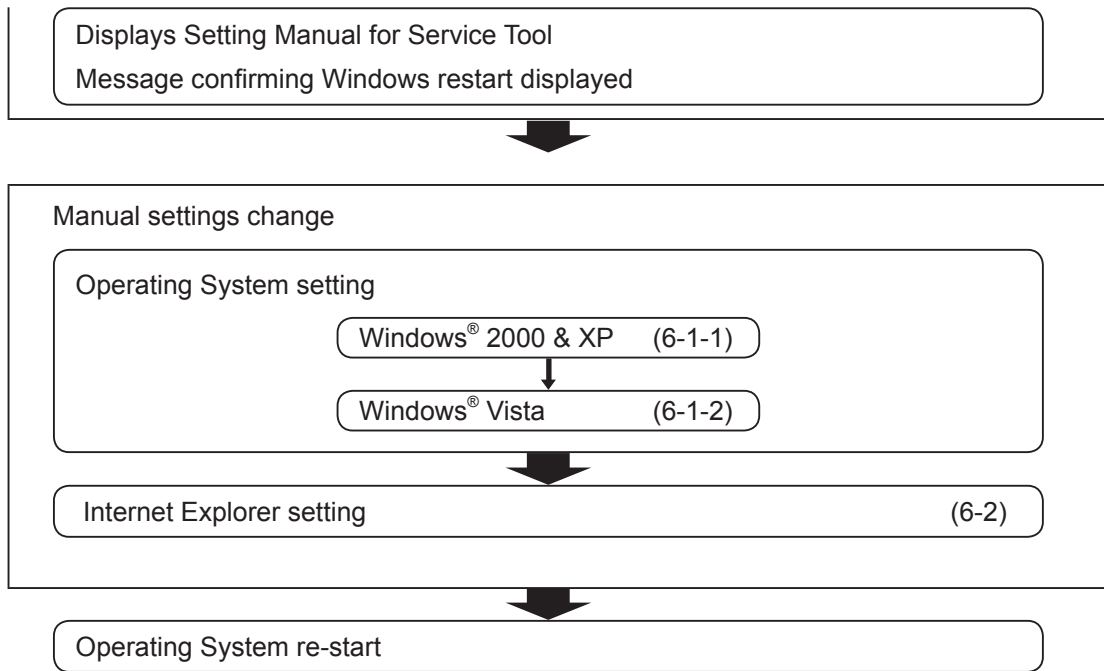

- Only English version MDAC and Microsoft® SQL Server 2005 Express component is compliant with this product. Operation cannot be guaranteed when other language version is used.
- Have installation performed by a user belonging to the Administrators group.

Contents

4. Hardware installation	14
4-1 Transmission adaptor installation	14
4-2 Turning on the power	15

4. Hardware installation

4-1 Transmission adaptor installation

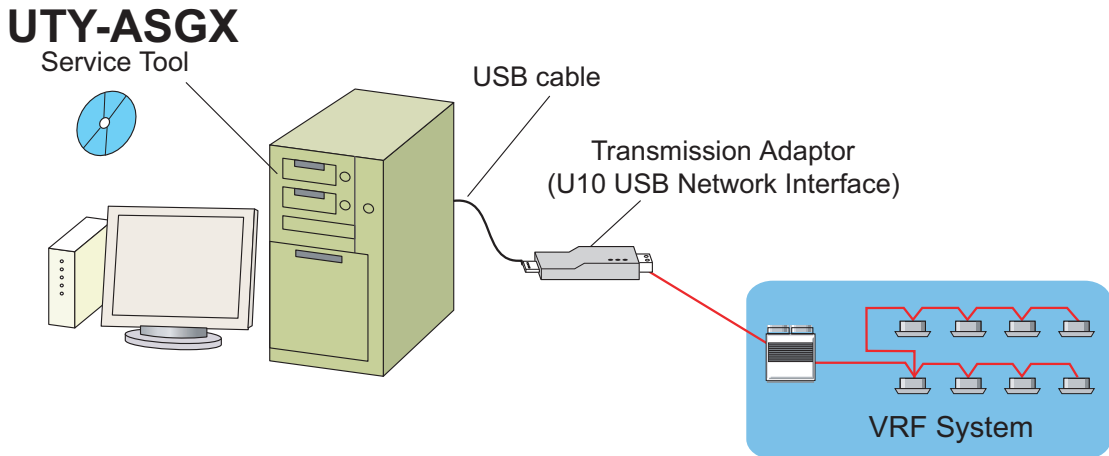

This transmission adaptor U10 USB Network Interface is connected using the USB port of a personal computer.

To use this product, turn on the power of the PC and install necessary drivers / software for this product (BEFORE connecting it to any USB port), following the *****QUICK START***** enclosed with this product.

4-2 Turning on the power

WARNING!

Do not turn on the power until all installation work is completed.

Once the wiring has been installed, the power can be turned on. Follow the procedure below for turning on the power.

- ① Turn on the power for all connected indoor units.
- ② Turn on the power for all connected outdoor units.
- ③ Connect U10 USB Network Interface
(Driver must installed following the procedure in section 4-1 before connecting). *1

Note *1  Make sure that USB equipment (USB hub, etc.) that this product is connected to, is not overloaded (power supplied thru the interface oes not exceeds the maximum limit).

- ④ Turn on the power for Service Tool PC, if it is not yet turned on.

Contents

5. Software Installation & Removal	18
5-1 Installation Notes	18
5-2 Software Installation	19
5-3 Software Removal	20
5-3-1 Windows® 2000 & XP	20
5-3-2 Windows® Vista	22

5. Software Installation & Removal

5-1 Installation Notes

Before starting the installation of this product, check each of the followings.

- Install Adobe Acrobat Reader (Ver. 4.0 or later) prior to the installation. (Adobe Acrobat Reader does not come with this product).
- Have the installation CD of the Windows version (Windows® XP, Windows® 2000 or Windows® Vista) used for the PC ready. This will be required during the installation of IIS. If the following screen is displayed during IIS setup, you must follow the instruction on the screen. If you cancel the installation, setup will not be completed properly.

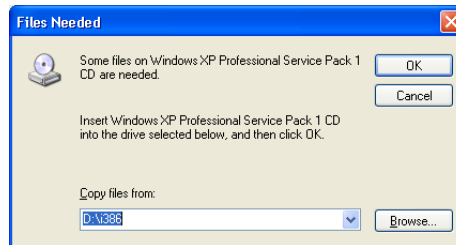
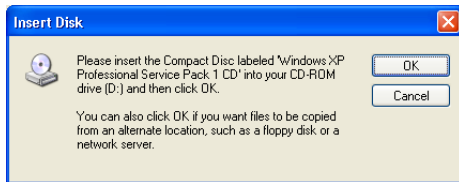

- If one of the following product is already installed, remove it first. Also remove it when re-installing other software components such as IIS, MSDE and WIBU-Key drivers. Refer “5-3 Software Removal” for how to remove these products.
 - Service Tool for VRF System (UTR-YSTC) Ver. 3.0 or later
 - Service Tool for VRF System (UTY-ASGX) Ver. 1.0
 - Web Monitoring Tool for VRF System (UTR-YMSA) Ver. 3.0 or later
 - Web Monitoring Tool for VRF System (UTY-AMGX) Ver. 1.0
- Do NOT insert WIBU-Key (Software protection key) enclosed with this product to the PC until product installation is completed.
- You are required to login to the computer as Administrator (or equivalent) to the PC to install this product.
- Stop all running programs before you start the installation.
- If Anti-Virus software product is installed, temporarily disable the software during the installation of this product.
- Please delete “Temporary Internet Files”.
 - IE menu [tools] → [Internet Options ...] → [General] tab → Press [Delete Files ...] button. If [Delete Files] message screen is displayed, check [Delete all offline content] and press “OK”.

5-2 Software Installation

- ① Insert the CD for the “Service Tool for VRF System Ver. 1.0” into the CD drive of the PC you are about to install. Installation program starts automatically.
- ② If installation program does not start, double click the “setup.exe” stored in the root directory of the CD drive with the mouse.

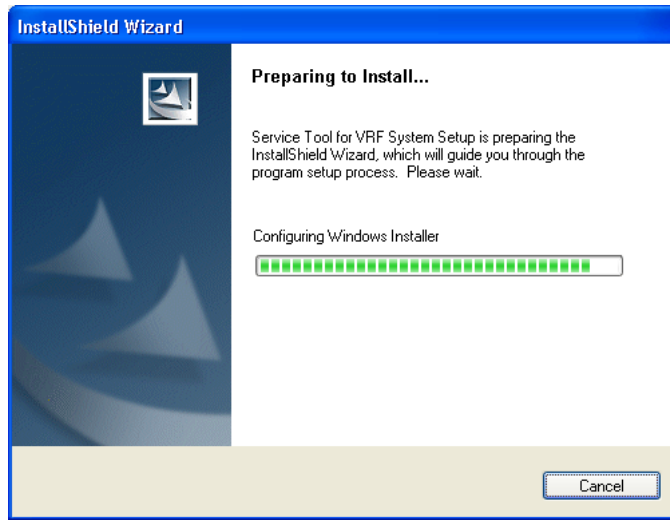

- ③ After installation starts, follow the direction on the screen, which will guide you through the installation.
- ④ When installation program ends, Setting Manual for this product and “Windows Restart Confirmation Message” will appear. If you have not completed the remaining setup procedures described in the next section (“6. Setting”) of the Setting Manual yet, do NOT restart the Windows. Complete the remaining setup procedures according to the description in the Setting Manual displayed on the screen first.

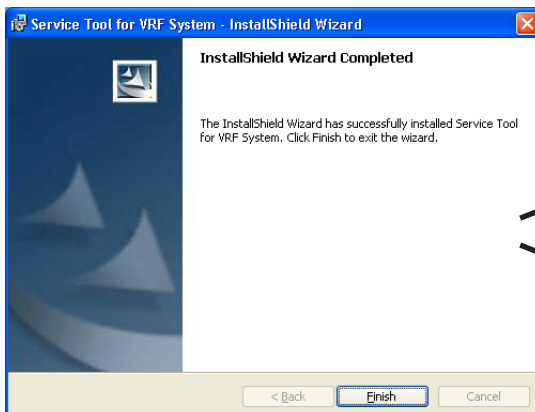

Displaying Setting manual (PDF file).

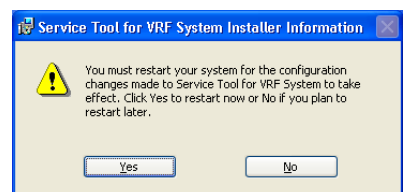

⑤ After all the setup is completed, restart the Windows®.

Note



- Operation to be performed after inserting WIBU-Key (Software protection key) and when the “Found New Hardware Wizard” screen appears.
 - 1 From the 3 Windows Update Options, select “No, not this time”. Then click “Next” to continue. This dialog may not always show.
 - 2 Select “Install the software automatically (Recommended).”. Then click “Next” to continue.
 - 3 When completion dialog appears, click “Finish”.
- When installing on Windows® Vista ,you may be asked for permission to continue with the operation.
In such cases, select “continue”.
- Some operation may take long time . Please wait at least a couple of minutes.

5-3 Software Removal

Before executing this procedure, be sure to stop the Service Tool program if it is running. Also, make sure that WIBU-Key is not inserted to the PC.

5-3-1 Windows® 2000 & XP

① Open  → [Control Panel] → [Add or Remove Programs], and then remove the following programs.

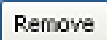
② Select the program to be removed from the list below and click  .

Target software	Program name
MSDE2000	Microsoft® SQL Server Desktop Engine
Microsoft SQL Server Express 2005	Microsoft® SQL Server 2005 Microsoft® SQL Server Native Client Microsoft® SQL Server Setup Support Files (English) Microsoft® SQL Server VSS Writer
WIBU-KEY	WIBU-KEY Setup (WIBU-KEY Remove)
Service Tool (UTR-YSTC) Service Tool (UTY-ASGX)	Service Tool for VRF System (Data acquisition) Service Tool for VRF System (Web) Service Tool for VRF System Service Tool for VRF System Ver x.x
Web Monitoring Tool (UTR-YMSA) Web Monitoring Tool (UTY-AMGX)	Web Monitoring Tool for VRF System (Data acquisition) Web Monitoring Tool for VRF System (Web) Web Monitoring Tool for VRF System Web Monitoring Tool for VRF System Ver x.x
U10 USB Network Interface driver	Echelon Open LDV x.x



Note

- Programs to be deleted depends on the version of Service Tool or Web Monitoring Tool that is already installed. Not all of the programs listed above may appear.
- If you have removed Microsoft SQL Server Express 2005, make sure that you have deleted the following installation folder.
[Target folder] Installation drive: \\Program files\Microsoft SQL Sever\MSSQL.1

- 3 Uninstall [IIS] from [Add/Remove Windows Components] of [Add/Remove Programs] in the Control Panel. (Remove “check” and follow the direction on the screen.)

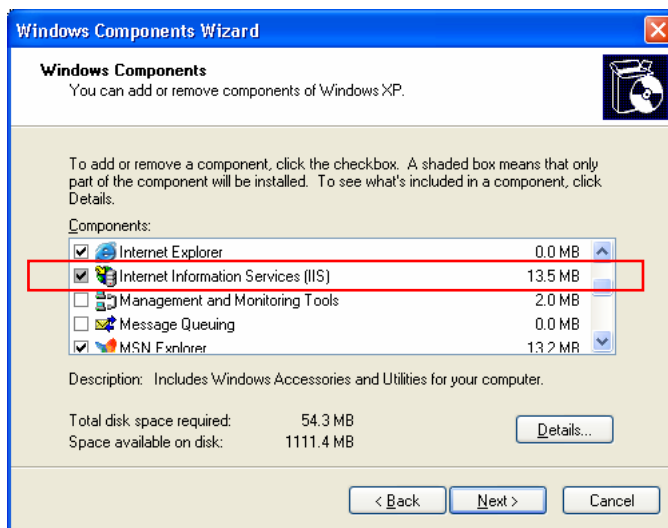



Note

For IIS, do not remove it unless there is a definite need. If for certain reason, you have to remove IIS, remove Service Tool/Web Monitoring Tool first before removing IIS.

- 4 If removal is completed, restart the Windows®.

5-3-2 Windows® Vista

① Open  →  → [Program and Features] and then remove the following programs.

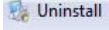
② Select the program to be removed from the list below and click  .

Target software	Program name
Service Tool	Service Tool for VRF System Ver x.x
Web Monitoring Tool	Web Monitoring Tool for VRF System Ver x.x
Microsoft SQL Server Express 2005	Microsoft® SQL Server 2005 Microsoft® SQL Server Native Client Microsoft® SQL Server Setup Support Files (English) Microsoft® SQL Server VSS Writer
U10 USB Network Interface driver	Echelon OpenLDV x.x
WIBU-KEY	WIBU-KEY Setup (WIBU-KEY Remove)

Note



- Programs to be deleted depends on the version of Service Tool or Web Monitoring Tool that is already installed. Not all of the programs listed above may appear.
- If you have removed Microsoft SQL Server Express 2005, make sure that you have deleted the following installation folder.
[Target folder] Installation drive: \\Program files\Microsoft SQL Sever\MSSQL.1

- ③ Turn off [Internet Information Service] from [Turn Windows features on or off] of [Programs and Features] in the Control Panel. (Clear corresponding check box, press “OK” and follow the direction on the screen.)
In the Control Panel, select “Classic View”.

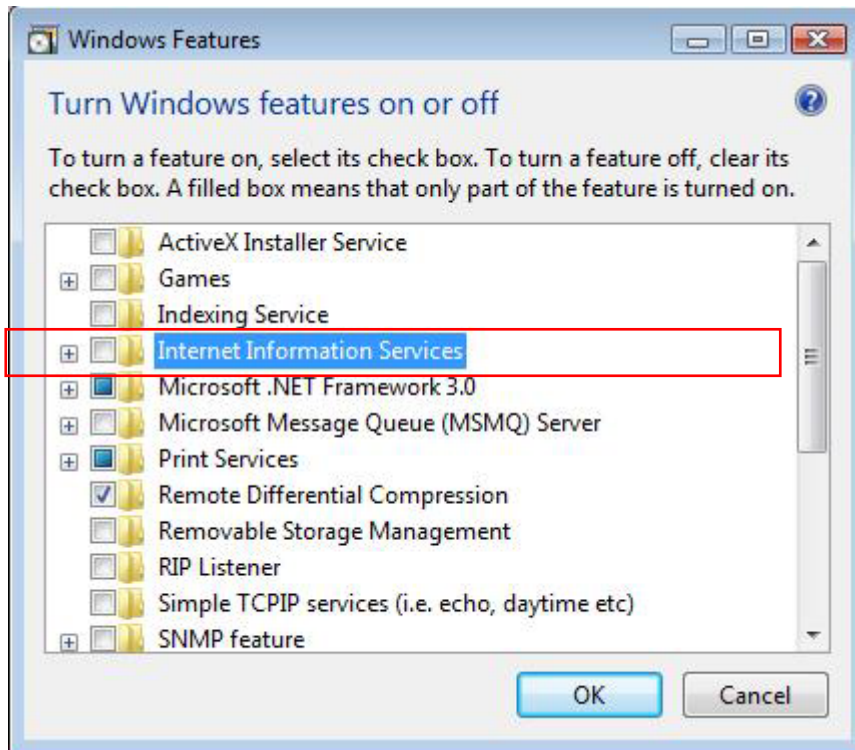

- ④ Restart the Windows.

Contents

6. Setting	26
6-1 Operating System setting	26
6-1-1 Windows® 2000 & XP	26
6-1-2 Windows® Vista	27
6-2 Internet Explorer setting	29

6. Setting

6-1 Operating System setting

6-1-1 Windows® 2000 & XP

- ① Open the regional setting screen by sequentially selecting the menus as follows:
[start] → [Control Panel] → [Date, Time, Language, and Regional Options]
→ [Regional and Language Options]



- When the control panel display format is Classic View, select the menus in the following order:

[start] → [Control Panel] → [Regional and Language Options]

- ② ③ The screen shown below is displayed.
Select English (United Kingdom) at the Standard and formats area of the Regional Options tab.

Select English (United Kingdom) at the Language for non-Unicode programs of the Advanced tab.

For Windows®2000 :Click Set default... button of the General tab.

Select English (United Kingdom) at the Select System Locale screen.

[Regional Options tab]

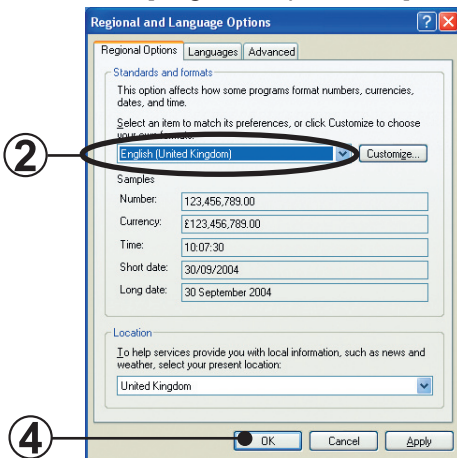

[Advanced tab]

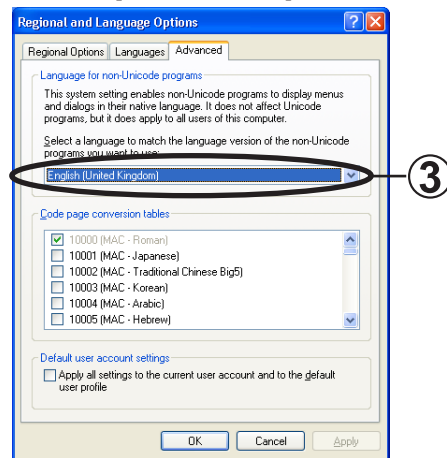

- Do not change the settings clicking the [Customize...] button. Set the settings as follows, if by chance, the current settings differs.

[Numbers].....Decimal symbol: “.” (dot)

[Time].....Time separator: “:” (colon)

[Date].....Date separator: “/” (slash)

- ④ Click .

6-1-2 Windows® Vista

■ Regional option

- 1 Open the regional setting screen by sequentially selecting the menu as follows.



- 2 The screen shown below is displayed.

Select English (United Kingdom) at the Current format area of the Formats tab.

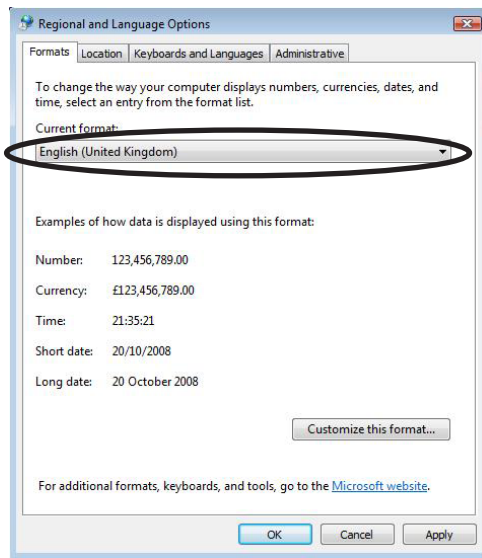

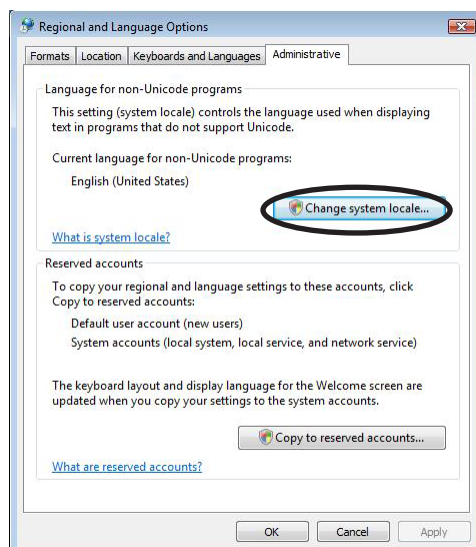

- 3 Select Administrative tab and click  in the Language for non-Unicode programs area.

If security confirmation screen appears, press "Continue".

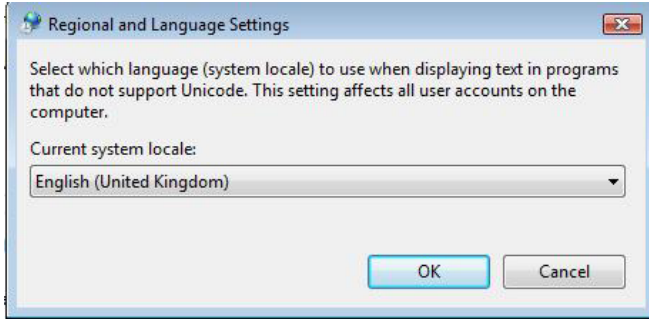

Select English (United Kingdom) for the Current system locale in the Regional and Language Settings and click  .



Note Do not change the settings clicking the [Customize...] button. Set the settings as follows, if by chance, the current settings differs.
 [Numbers].....Decimal symbol: "."(dot)
[Time].....Time separator. ":"(colon)
[Date].....Date separator: "/"(slash)

4 Click  .

6-2 Internet Explorer setting

- 1 Start Internet Explorer, and select the following from the menu bar.
[Tools] → [Internet Options...]



- Internet Explorer 7 setting

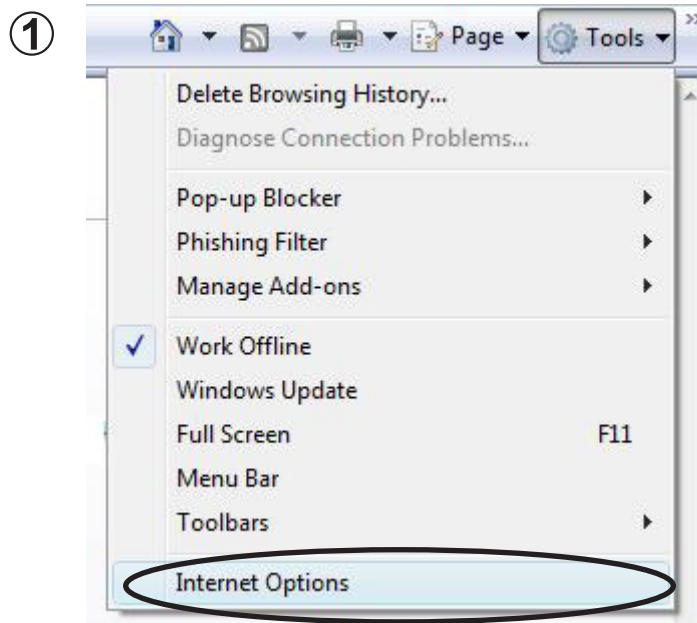

- ② The screen shown below is displayed.
Select the Security tab.

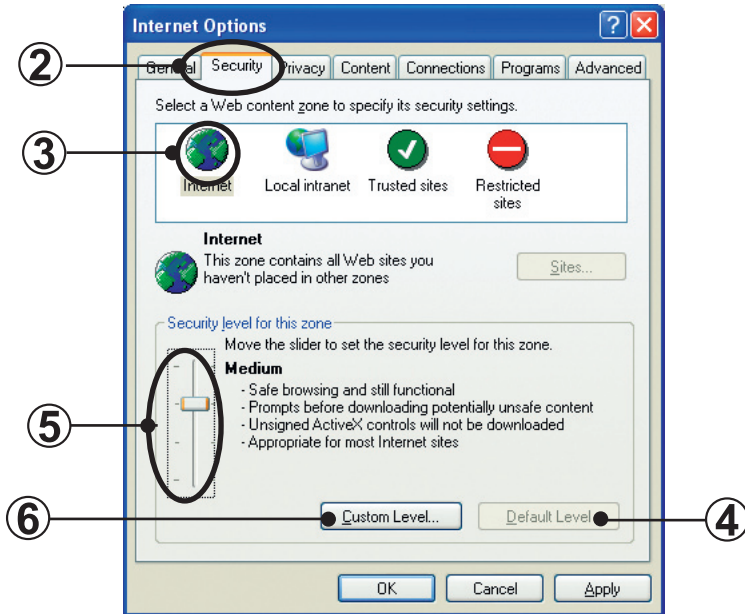

- ③ Select Internet.

- ④ Click .

- ⑤ Set the slider that indicates the Security Level to Medium or Medium-high.

- ⑥ For Windows® XP SP2 and later versions or for Windows® Vista, perform steps ⑥ thru ⑨ .
Otherwise, advance to step ⑩ .

Click .

- ⑦ The screen shown below is displayed.
Set "Allow script-initiated windows without size or position constraints" to Enable.

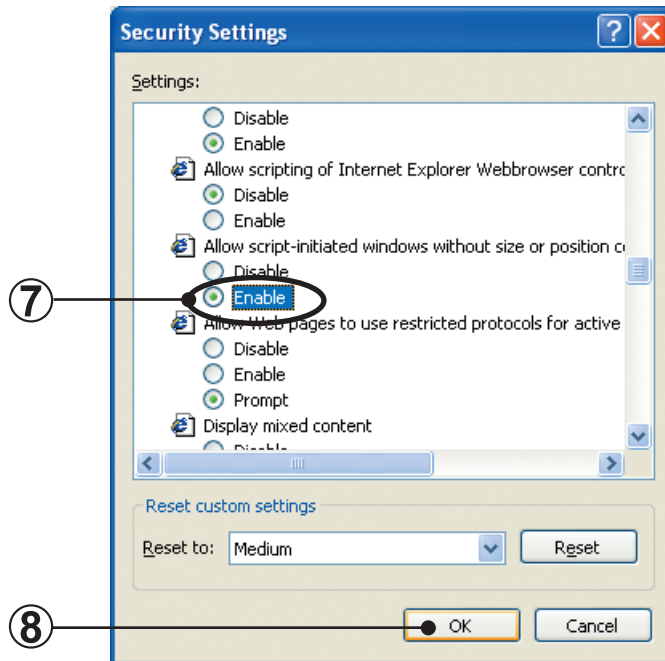

- ⑧ Click .

- ⑨ The screen shown below is displayed.
Click .

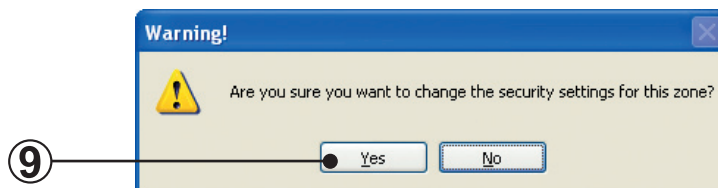

- 10 The screen shown below is displayed.
Select the Connections tab.

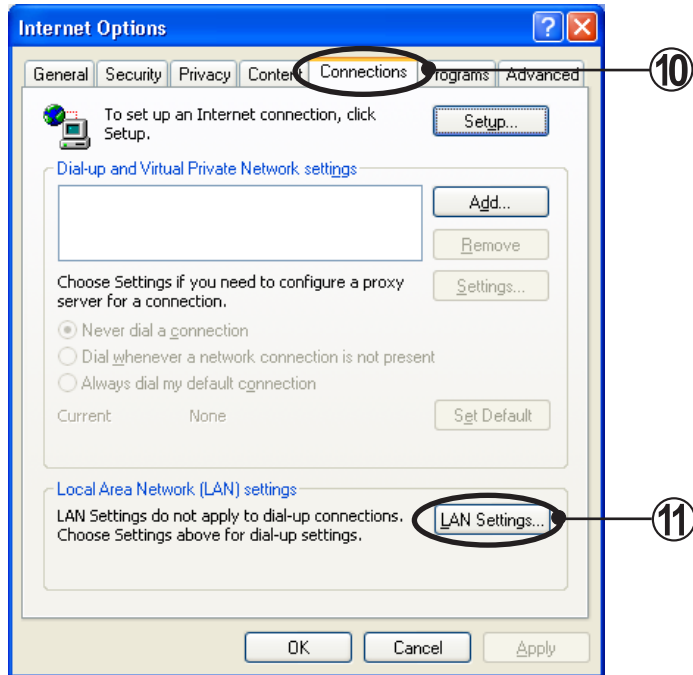

- 11 Click **LAN Settings...** .

- 12 The screen shown below is displayed.
If you are using a proxy server, check on the [Bypass proxy server for local addresses]
and press **OK** .

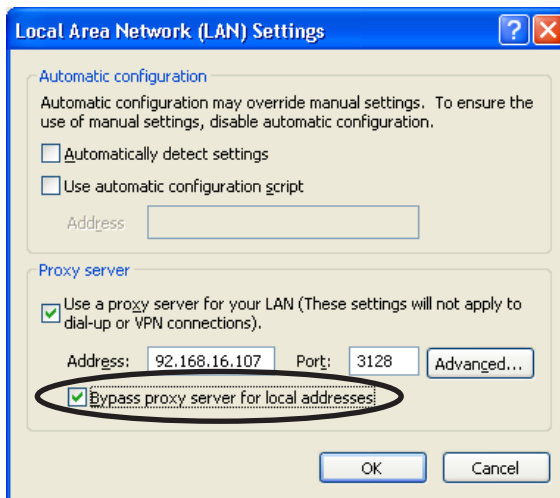

- 13 For Windows® Vista or Internet Explorer 7 do the following. Select the Security tab, press “Custom level...”.

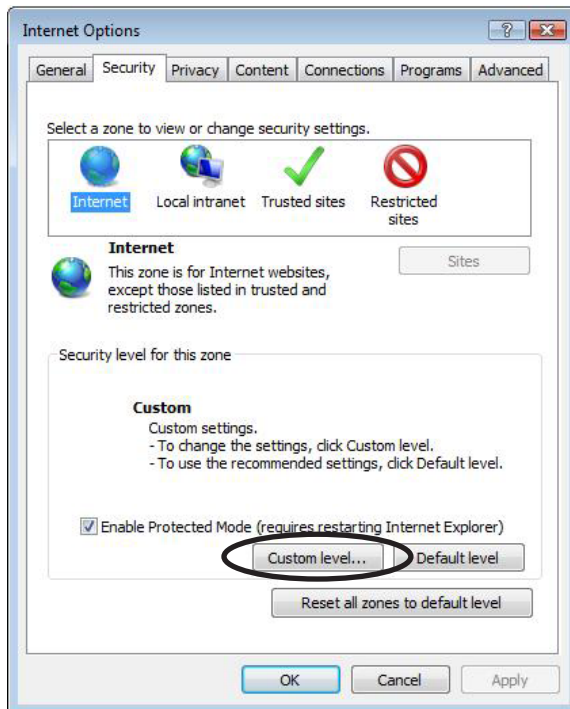

Select enable for “Automatic prompting for file downloads”.

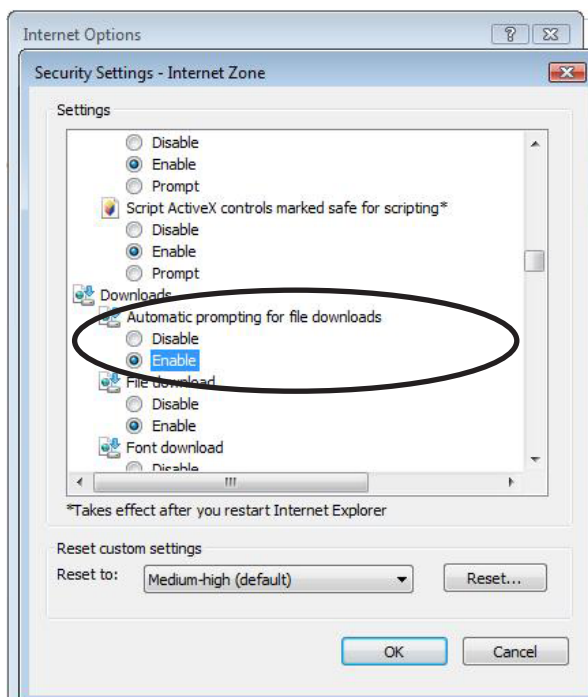

Select enable for “Allow websites to open windows without address or status bars”.

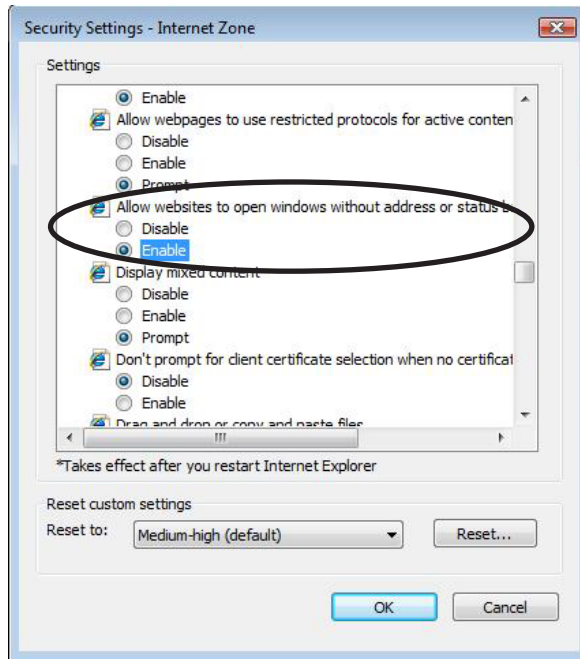

14 Finish setup by clicking in the Internet Options window.

Trademarks

- Echelon[®], LON[®], LONWORKS[®], LONMARK[®], LonBuilder[®], NodeBuilder[®], LonManager[®], LonTalk[®], LonUsers[®], LonPoint[®], Digital Home[®], Neuron[®], 3120[®], 3150[®], LNS[®], i.LON[®], LONWORLD[®], ShortStack[®], Panoramix[®], LonMaker[®], the Echelon logo, and the LonUsers logo are trademarks of Echelon Corporation registered in the United States and other countries.
- Microsoft[®], Windows[®] are a registered trademark of Microsoft[®] Corporation in the United States and other countries.
- Intel[®], Celeron[®] and Pentium[®] are trademarks or registered trademarks of Intel Corporation or its subsidiaries in the United States and other countries.
- AMD Athlon[™], AMD Duron[™] are trademarks of Advanced Micro Devices, Inc.
- Adobe[®], Acrobat Reader[®] are either registered trademarks or trademarks of Adobe Systems Incorporated in the United States and/or other countries.
- WIBU is a registered trademark of WIBU-SYSTEMS AG.

